

# CRYOGENIC VALVES

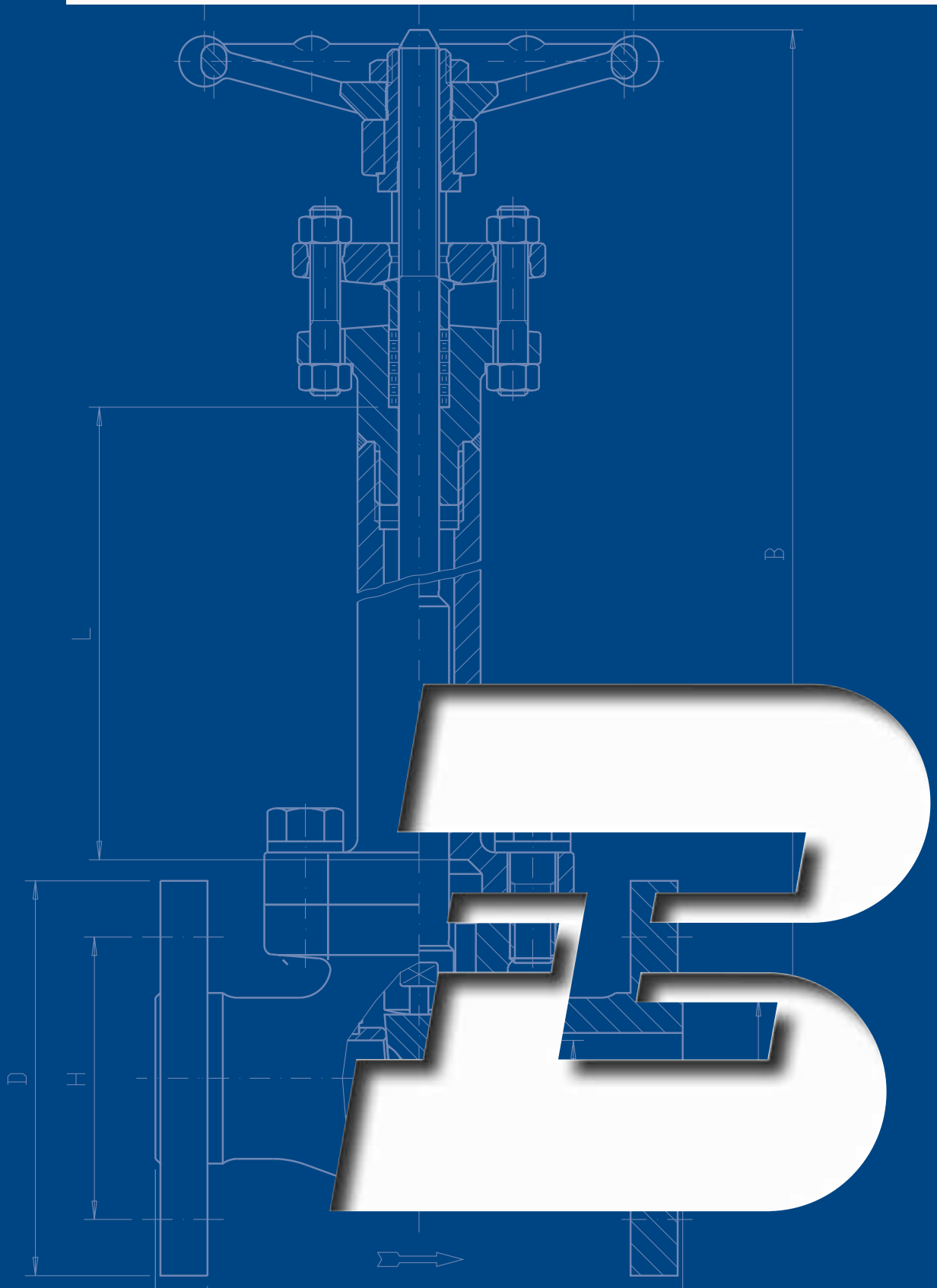

# CRYOGENIC VALVES

## GATE VALVES

### BOLTED BONNET

CLASS	FIGURE
150 FB	1C 100
150 RB	1CL 100
300 FB	3C 100
300 RB	3CL 100
600 FB	6C 100
600 RB	6CL 100
800 FB	C 100
800 RB	CL 100
1500 FB	9C 100
1500 RB	9CL 100
1500 FB	15CRR 100

### WELDED BONNET

CLASS	FIGURE
150 FB	1CWH 100
150 RB	1CWHL 100
300 FB	3CWH 100
300 RB	3CWHL 100
600 FB	6CWH 100
600 RB	6CWHL 100
800 FB	CW 100
800 RB	CWL 100
1500 FB	9CW 100
1500 RB	9CWL 100
1500 FB	15CWHR 100

## GLOBE VALVES

### BOLTED BONNET

CLASS	FIGURE
150 FB	1C 300
150 RB	1CL 300
300 FB	3C 300
300 RB	3CL 300
600 FB	6C 300
600 RB	6CL 300
800 FB	C 300
800 RB	CL 300
1500 FB	9C 300
1500 RB	9CL 300
1500 FB	15CRR 300

### WELDED BONNET

CLASS	FIGURE
150 FB	1CWH 300
150 RB	1CWHL 300
300 FB	3CWH 300
300 RB	3CWHL 300
600 FB	6CWH 300
600 RB	6CWHL 300
800 FB	CW 300
800 RB	CWL 300
1500 FB	9CW 300
1500 RB	9CWL 300
1500 FB	15CWHR 300

# CRYOGENIC VALVES

**CLASS 150-300-600-800-1500**

FOR COLD SERVICE (-196°C) - GATE and GLOBE Type - BOLTED BONNET/WELDED BONNET - Full and reduced bore

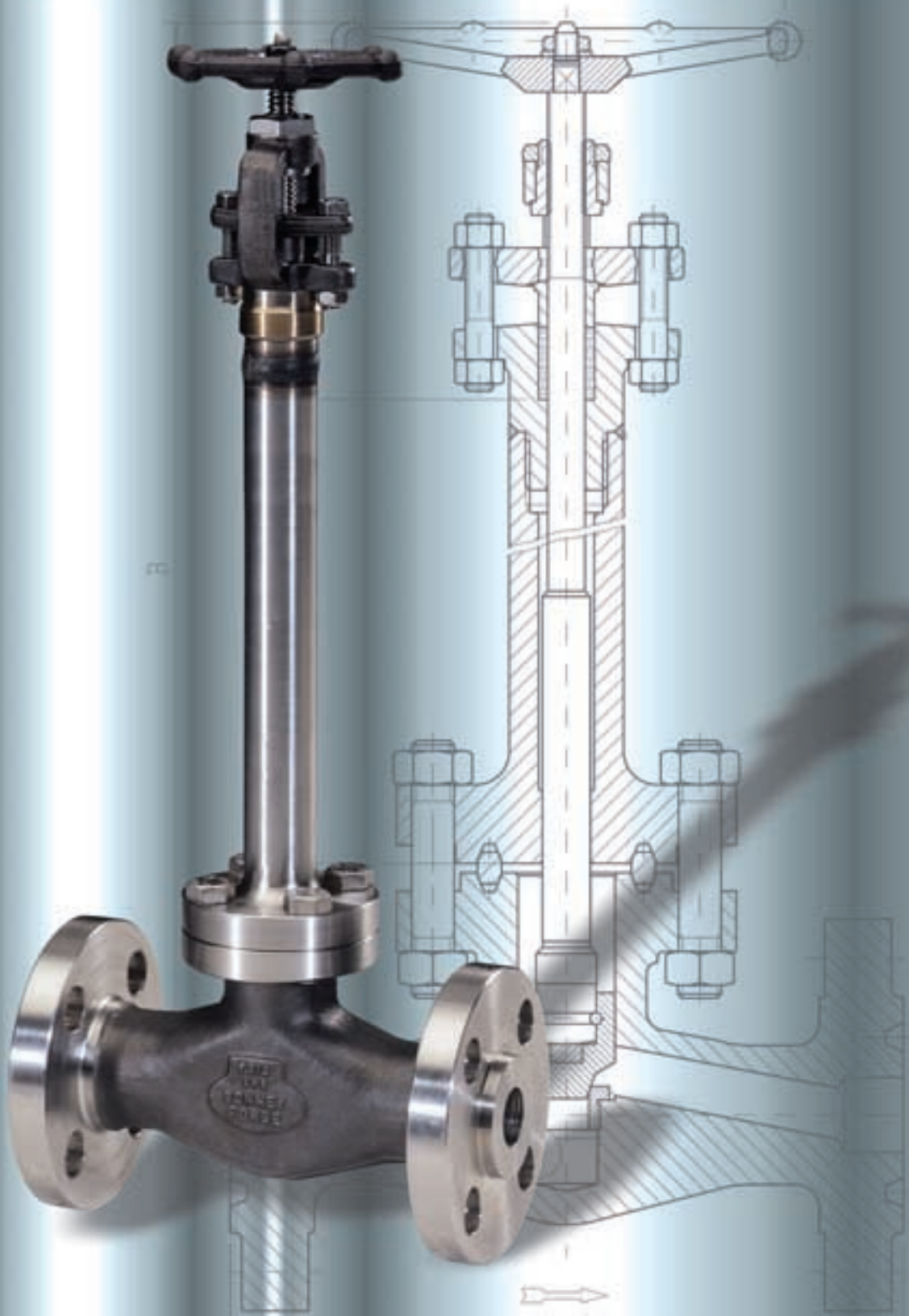

## GATE VALVES

### CLASS 150

FULL BORE - Type 1C 100						
SIZE	inch	1/2	3/4	1	1.1/2	2
	mm	15	20	25	40	50
A		108	117,5	127	165	178
B open		430	445	470	535	595
C		88	97	138	138	172
F		14	18	24	36,6	48
WEIGHT kg ≅		4,8	5,9	8,7	14,7	19
FIGURE		1C 103	1C 104	1C 105	1C 107	1C 108
PACKING		BH2	BH4	BH5	BY5/A	BH8
GASKET		G2	G3	G4	G7	G8

REDUCED BORE - Type 1CL 100						
SIZE	inch	1/2	3/4	1	1.1/2	2
	mm	15	20	25	40	50
A		108	117,5	127	165	178
B open		420	435	450	510	535
C		88	88	97	138	138
F		9,6	14	18	30	36,6
WEIGHT kg ≅		4,3	5,1	6,4	12,4	16
FIGURE		1CL 103	1CL 104	1CL 105	1CL 107	1CL 108
PACKING		BH2	BH2	BH4	BH6/A	BY5/A
GASKET		G2	G2	G3	G5	G7

### CLASS 300

FULL BORE - Type 3C 100						
SIZE	inch	1/2	3/4	1	1.1/2	2
	mm	15	20	25	40	50
A		140	152,5	165	191	216
B open		430	445	470	535	595
C		88	97	138	138	172
F		14	18	24	36,6	48
WEIGHT kg ≅		5,1	7,2	9,9	16	22
FIGURE		3C 103	3C 104	3C 105	3C 107	3C 108
PACKING		BH2	BH4	BH5	BY5/A	BH8
GASKET		G2	G3	G4	G7	G8

REDUCED BORE - Type 3CL 100						
SIZE	inch	1/2	3/4	1	1.1/2	2
	mm	15	20	25	40	50
A		140	152,5	165	191	216
B open		420	435	450	510	535
C		88	88	97	138	138
F		9,6	14	18	30	36,6
WEIGHT kg ≅		5,1	6,5	7,8	15	19
FIGURE		3CL 103	3CL 104	3CL 105	3CL 107	3CL 108
PACKING		BH2	BH2	BH4	BH6/A	BY5/A
GASKET		G2	G2	G3	G5	G7

### CLASS 600

FULL BORE - Type 6C 100						
SIZE	inch	1/2	3/4	1	1.1/2	2
	mm	15	20	25	40	50
A		165	191	216	241	292
B open		430	445	470	535	595
C		88	97	138	138	172
F		14	18	24	36,6	48
WEIGHT kg ≅		6,2	8,4	10,5	20	32
FIGURE		6C 103	6C 104	6C 105	6C 107	6C 108
PACKING		BH2	BH4	BH5	BY5/A	BH8
GASKET		G2	G3	G4	G7	G9

REDUCED BORE - Type 6CL 100						
SIZE	inch	1/2	3/4	1	1.1/2	2
	mm	15	20	25	40	50
A		165	191	216	241	292
B open		420	435	450	510	535
C		88	88	97	138	138
F		9,6	14	18	30	36,6
WEIGHT kg ≅		5,3	7,4	9,8	18	24
FIGURE		6CL 103	6CL 104	6CL 105	6CL 107	6CL 108
PACKING		BH2	BH2	BH4	BH6/A	BY5/A
GASKET		G2	G2	G3	G6	G7

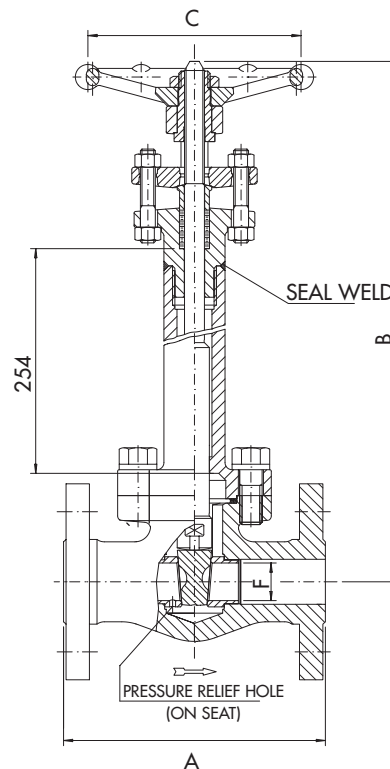

Outside Screw and Yoke (OS&Y)  
Self aligning packing gland in two parts

Pressure relief hole on seat (for Gate Valves only)  
Welded body-bonnet joint also available

Spiral-wound gasket retained type  
Integral backseat

## GATE VALVES

### CLASS 800

FULL BORE - Type C 100									
SIZE	inch	1/4	3/8	1/2	3/4	1	1.1/4	1.1/2	2
	mm	6	10	15	20	25	32	40	50
A		80	80	90	110	127	127	127	210
B open		400	400	400	445	475	505	530	598
C		88	88	88	97	138	138	138	172
F		8	9,6	14	18	24	30	36,6	48
G		32	32	38	48	56	64	78	85
WEIGHT kg ≅		3,4	3,4	3,5	5,1	8,2	12	16	23
FIGURE		C 101	C 102	C 103	C 104	C 105	C 106	C 107	C 108
PACKING		BH2	BH2	BH2	BH4	BH5	BH6/A	BY5/A	BH8
GASKET		G2	G2	G2	G3	G4	G6	G7	G9

REDUCED BORE - Type CL 100						
SIZE	inch	1/2	3/4	1	1.1/2	2
	mm	15	20	25	40	50
A		80	90	110	127	127
B open		400	400	445	505	530
C		88	88	97	138	138
F		9,6	14	18	30	36,6
G		32	38	48	64	78
WEIGHT kg ≅		3,4	3,5	5	9,6	12,5
FIGURE		CL 103	CL 104	CL 105	CL 107	CL 108
PACKING		BH2	BH2	BH4	BH6/A	BY5/A
GASKET		G2	G2	G3	G6	G7

### CLASS 1500

FULL BORE - Type 9C 100									
SIZE	inch	1/4	3/8	1/2	3/4	1	1.1/4	1.1/2	2
	mm	6	10	15	20	25	32	40	50
A		90	90	110	127	127	127	210	230
B open		395	395	435	470	495	520	585	620
C		88	88	97	138	138	138	172	234
F		8	9,6	14	18	24	30	36,6	48
G		38	38	48	56	64	78	85	95
WEIGHT kg ≅		3,5	3,5	5,5	7,8	11	14,5	25,6	43
FIGURE		9C 101	9C 102	9C 103	9C 104	9C 105	9C 106	9C 107	9C 108
PACKING		BH3	BH3	BH5	BH6/A	2B4/A	BY7	2B5	9B8/A
GASKET		G1	G1	G2	G3	G4	G5	G7	G8

REDUCED BORE - Type 9CL 100						
SIZE	inch	1/2	3/4	1	1.1/2	2
	mm	15	20	25	40	50
A		90	110	127	127	210
B open		405	440	470	525	590
C		88	97	138	138	172
F		9,6	14	18	30	36,6
G		32	38	48	64	78
WEIGHT kg ≅		3,7	5,3	8,5	13,6	26
FIGURE		9CL 103	9CL 104	9CL 105	9CL 107	9CL 108
PACKING		BH3	BH5	BH6/A	2B5	BH8
GASKET		G1	G2	G3	G5	G7

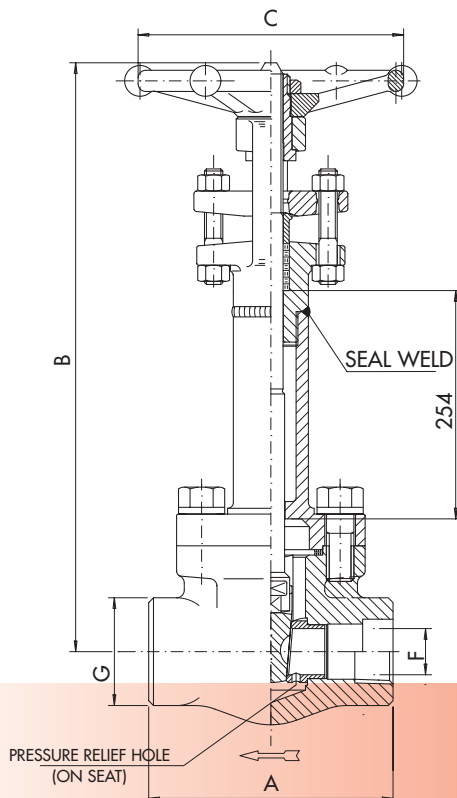

## CRYOGENIC VALVES

## GLOBE VALVES

### CLASS 150

FULL BORE - Type 1C 300						
SIZE	inch	1/2	3/4	1	1.1/2	2
	mm	15	20	25	40	50
A		108	117,5	127	165	203
B open		445	470	500	560	630
C		88	97	138	138	172
F		13	17,5	22,5	35	45
WEIGHT kg $\cong$		4,8	5,9	8,7	14,7	21
FIGURE		1C 303	1C 304	1C 305	1C 307	1C 308
PACKING		BH3	BH5	BY5/A	BY7	BY7
GASKET		G2	G3	G4	G7	G8

REDUCED BORE - Type 1CL 300						
SIZE	inch	1/2	3/4	1	1.1/2	2
	mm	15	20	25	40	50
A		108	117,5	127	165	203
B open		385	435	460	515	545
C		88	88	97	138	172
F		9	13	17,5	29,5	35
WEIGHT kg $\cong$		4,6	5,2	6,7	12,5	19
FIGURE		1CL 303	1CL 304	1CL 305	1CL 307	1CL 308
PACKING		BH3	BH3	BH5	BY5/A	BY7
GASKET		G2	G2	G3	G5	G8

### CLASS 300

FULL BORE - Type 3C 300						
SIZE	inch	1/2	3/4	1	1.1/2	2
	mm	15	20	25	40	50
A		152,5	178	203	229	267
B open		420	460	510	550	610
C		88	97	138	172	172
F		13	17,5	22,5	35	45
WEIGHT kg $\cong$		6,2	7,9	12	21	31
FIGURE		3C 303	3C 304	3C 305	3C 307	3C 308
PACKING		BH3	BH5	BY5/A	BY7	BH8
GASKET		G2	G3	G4	G7	G9

REDUCED BORE - Type 3CL 300						
SIZE	inch	1/2	3/4	1	1.1/2	2
	mm	15	20	25	40	50
A		152,5	178	203	229	267
B open		390	440	480	540	565
C		88	88	97	138	172
F		9	13	17,5	29,5	35
WEIGHT kg $\cong$		5,6	6,7	9,8	17,5	24,5
FIGURE		3CL 303	3CL 304	3CL 305	3CL 307	3CL 308
PACKING		BH3	BH3	BH5	BY5/A	BY7
GASKET		G2	G2	G3	G6	G7

### CLASS 600

FULL BORE - Type 6C 300						
SIZE	inch	1/2	3/4	1	1.1/2	2
	mm	15	20	25	40	50
A		165	191	216	241	292
B open		420	460	510	550	610
C		88	97	138	172	172
F		13	17,5	22,5	35	45
WEIGHT kg $\cong$		6,5	8,7	12,6	22	34
FIGURE		6C 303	6C 304	6C 305	6C 307	6C 308
PACKING		BH3	BH5	BY5/A	BY7	BH8
GASKET		G2	G3	G4	G7	G9

REDUCED BORE - Type 6CL 300						
SIZE	inch	1/2	3/4	1	1.1/2	2
	mm	15	20	25	40	50
A		165	191	216	241	292
B open		390	440	480	540	565
C		88	88	97	138	172
F		9	13	17,5	29,5	35
WEIGHT kg $\cong$		5,9	7,6	10,2	19	26
FIGURE		6CL 303	6CL 304	6CL 305	6CL 307	6CL 308
PACKING		BH3	BH3	BH5	BY5/A	BY7
GASKET		G2	G2	G3	G6	G7

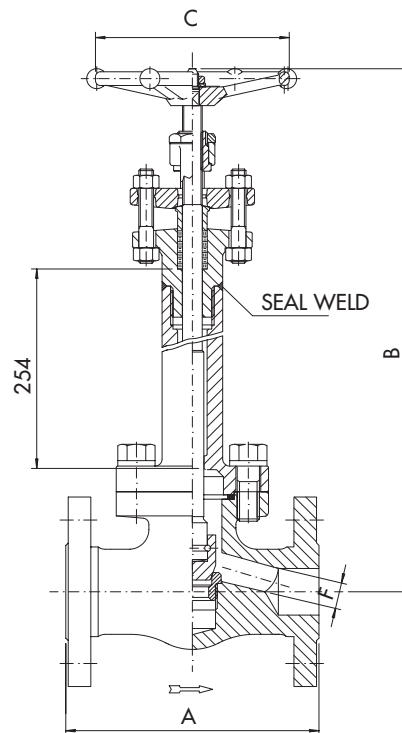

Face to face dimensions for class 800 and 1500  
socket weld and screwed ends according  
to B.F.E. standard

Socket weld Ends to ANSI B16.11  
Screwed Ends (NPT) to ANSI B1.20.1  
Butt Welding Ends to ANSI B.16.25

## GLOBE VALVES

### CLASS 800

FULL BORE - Type C 300									
SIZE	inch	1/4	3/8	1/2	3/4	1	1.1/4	1.1/2	2
	mm	6	10	15	20	25	32	40	50
A		80	80	90	110	127	150	180	210
B open		415	415	420	460	495	505	540	615
C		88	88	88	97	138	138	172	172
F		7	9	13	17,5	22,5	29,5	35	45
G		32	32	38	48	56	64	78	85
WEIGHT kg ≅		3,5	3,5	3,6	5,1	8,4	12,6	16,5	24
FIGURE		C 301	C 302	C 303	C 304	C 305	C 306	C 307	C 308
PACKING		BH3	BH3	BH3	BH5	BY5/A	BY5/A	BY7	BH8
GASKET		G2	G2	G2	G3	G4	G6	G7	G9

REDUCED BORE - Type CL 300						
SIZE	inch	1/2	3/4	1	1.1/2	2
	mm	15	20	25	40	50
A		80	90	110	150	180
B open		415	420	460	506	540
C		88	88	97	138	172
F		9	13	17,5	29,5	35
G		32	38	48	64	78
WEIGHT kg ≅		3,3	3,8	5,2	9,8	14,8
FIGURE		CL 303	CL 304	CL 305	CL 307	CL 308
PACKING		BH3	BH3	BH5	BY5/A	BY7
GASKET		G2	G2	G3	G6	G7

### CLASS 1500

FULL BORE - Type 9C 300									
SIZE	inch	1/4	3/8	1/2	3/4	1	1.1/4	1.1/2	2
	mm	6	10	15	20	25	32	40	50
A		90	90	110	127	150	180	210	230
B open		410	410	455	495	500	540	615	645
C		88	88	97	138	138	172	172	234
F		7	9	12	15	20	27	32	40
G		38	38	48	56	64	78	85	95
WEIGHT kg ≅		4	4	5,5	8	11	15,5	25	41
FIGURE		9C 301	9C 302	9C 303	9C 304	9C 305	9C 306	9C 307	9C 308
PACKING		BH3	BH3	BH5	2B4/A	2B4/A	2B5	BH8	9B8/A
GASKET		G1	G1	G2	G3	G4	G5	G7	G8

REDUCED BORE - Type 9CL 300						
SIZE	inch	1/2	3/4	1	1.1/2	2
	mm	15	20	25	40	50
A		90	110	150	180	210
B open		415	455	498	550	615
C		88	97	138	172	172
F		9	12	15	27	32
G		38	48	56	78	85
WEIGHT kg ≅		3,7	5,4	8,9	15,8	27,5
FIGURE		9CL 303	9CL 304	9CL 305	9CL 307	9CL 308
PACKING		BH3	BH5	2B4/A	2B5	BH8
GASKET		G1	G2	G3	G5	G7

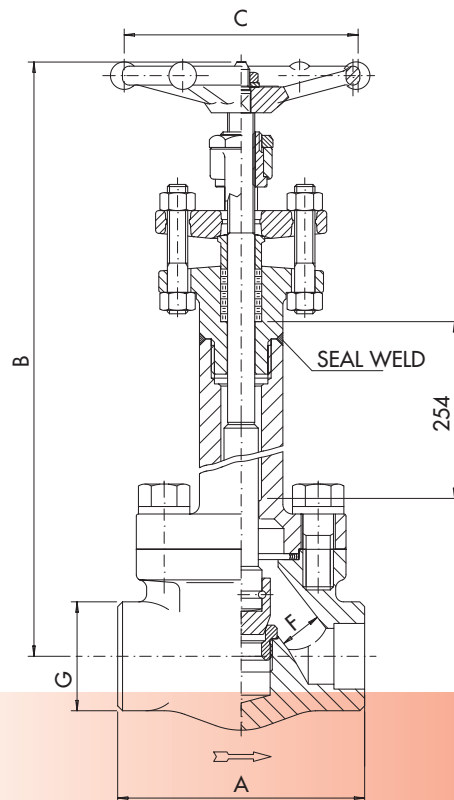

## CRYOGENIC VALVES

End flanges according to ANSI B16.5  
 For special execution see special features  
 For materials and testing pressure see technical data

Special testing equipments are used to test the valves  
 at a temperature of -196°C

## GATE VALVES

CLASS 1500						
FULL BORE - Type 15CRR 100						
SIZE	inch	1/2	3/4	1	1.1/2	2
A	mm	15	20	25	40	50
A		216	229	254	305	371,5
B open		455	490	500	575	630
C		97	138	138	172	234
F		14	18	24	36,6	48
WEIGHT kg ≅		10,2	14	17,5	31	59
FIGURE		15CRR 103	15CRR 104	15CRR 105	15CRR 107	15CRR 108
PACKING		BH5	BH6/A	2B4/A	BH8	4B8
GASKET		R12	R16	R16	R20	R22

## GLOBE VALVES

CLASS 1500						
FULL BORE - Type 15CRR 300						
SIZE	inch	1/2	3/4	1	1.1/2	2
A	mm	15	20	25	40	50
A		216	229	254	305	371,5
B open		470	510	525	595	650
C		97	138	138	172	234
F		12	14,5	19	31	40
WEIGHT kg ≅		10,5	14	18,5	32,5	62
FIGURE		15CRR 303	15CRR 304	15CRR 305	15CRR 307	15CRR 308
PACKING		BH5	2B4/A	2B4/A	BH8	9B8/A
GASKET		R12	R16	R16	R20	R22

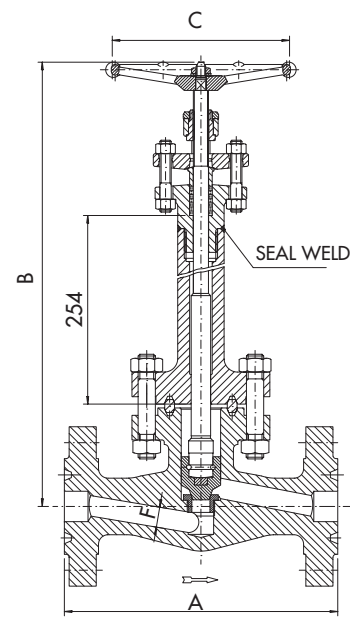
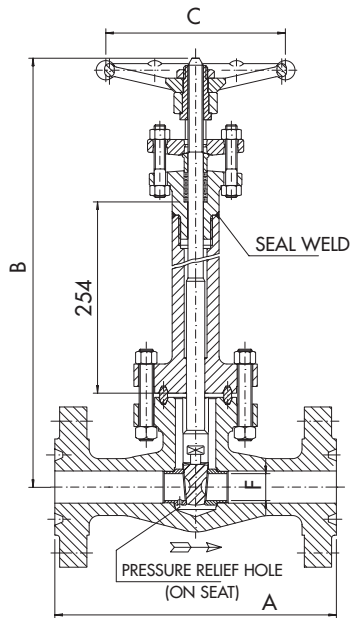

Typical drawing for Welded Bonnet

