

BELLOWS SEALED VALVES

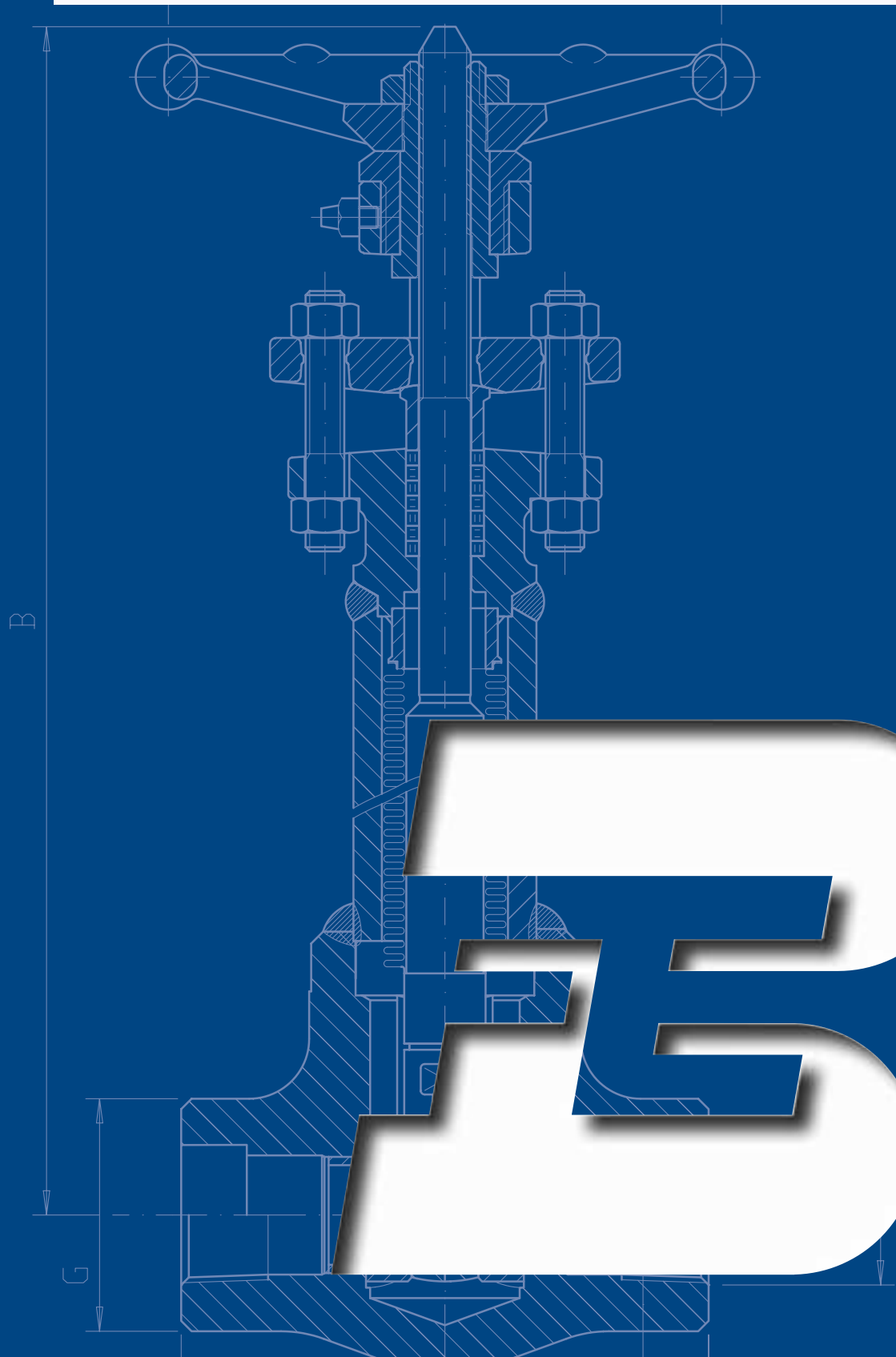

BELLOWS SEALED VALVES

GATE VALVES

CLASS	FIGURE	
	Bolted Bonnet	Welded Bonnet
800 FB	S 100	SHW 100
800 RB	SL 100	SHWL 100
1500 FB	9S 100	9SHW 100
1500 RB	9SL 100	9SHWL 100
2500 FB	S25HR 100	S25X 100

GLOBE VALVES

CLASS	FIGURE	
	Bolted Bonnet	Welded Bonnet
800 FB	S 300	SHW 300
800 RB	SL 300	SHWL 300
1500 FB	9S 300	9SHW 300
1500 RB	9SL 300	9SHWL 300
2500 FB	S25HR 300	S25X 300
2500 FB	-	S25YX 300

BELLOWS SEALED VALVES

CLASS 800-1500-2500

GATE and GLOBE Type - BOLTED BONNET/WELDED BONNET - Full and reduced bore

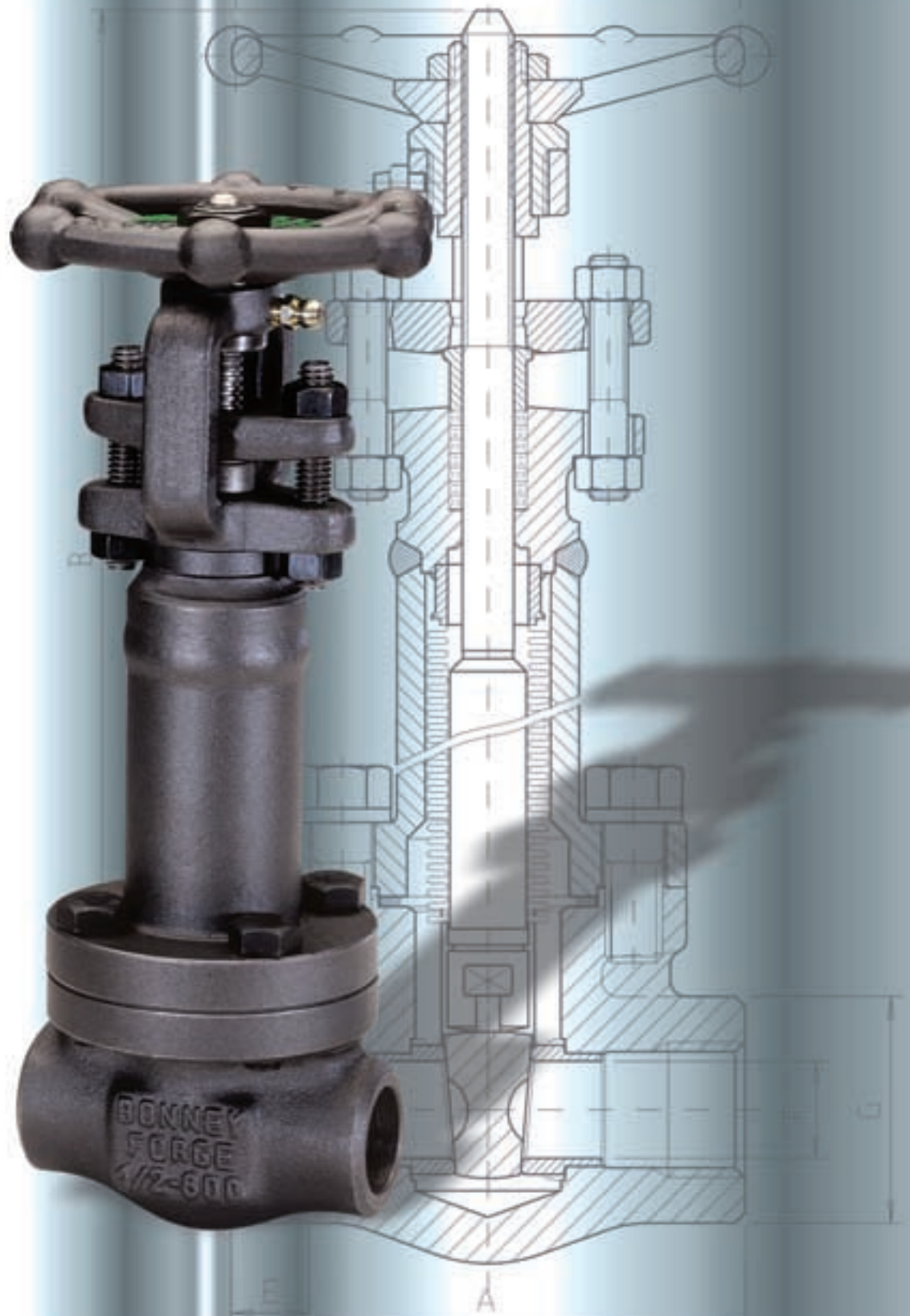

Applicable standards specifications:
BS 5352 - ANSI B16.34

Outside Screw and Yoke (OS&Y)
Self aligning packing gland in two parts
Spiral wound gasket retained type
Integral Backseat
Top entry type (only for classes 1500 and 2500)
Grease nipple for stem

GATE VALVES

CLASS 800

FULL BORE - Type S 100 - SHW 100									
SIZE	inch	1/4	3/8	1/2	3/4	1	1.1/4	1.1/2	2
	mm	6	10	15	20	25	32	40	50
A		80	80	90	110	127	127	127	210
B open		230	230	234	285	325	370	435	530
C		88	88	88	97	138	138	138	172
F		8	9,6	14	18	24	30	36,6	48
G		32	32	38	48	56	64	78	85
W. kg \cong Bolted B.		2,7	2,7	2,9	4,6	7,2	10	12,8	22
W. kg \cong Welded B.		2,3	2,3	2,5	3,8	6,2	8,4	11,2	20
FIGURE Bolted B.		S 101	S 102	S 103	S 104	S 105	S 106	S 107	S 108
FIGURE Welded B.		SHW 101	SHW 102	SHW 103	SHW 104	SHW 105	SHW 106	SHW 107	SHW 108
PACKING		BH2	BH2	BH2	BH4	BH5	BH6/A	BY5	BH8
GASKET*		G2	G2	G2	G3	G4	G6	G7	G9

REDUCED BORE - Type SL 100 - SHWL 100						
SIZE	inch	1/2	3/4	1	1.1/2	2
	mm	15	20	25	40	50
A		80	90	110	127	127
B open		230	234	285	370	435
C		88	88	97	138	138
F		9,6	14	18	30	36,6
G		32	38	48	64	78
W. kg \cong Bolted B.		2,7	3	4,4	9,4	12,3
W. kg \cong Welded B.		2,1	2,4	3,9	8,6	11
FIGURE Bolted B.		SL 103	SL 104	SL 105	SL 107	SL 108
FIGURE Welded B.		SHWL 103	SHWL 104	SHWL 105	SHWL 107	SHWL 108
PACKING		BH2	BH2	BH4	BH6/A	BY5
GASKET*		G2	G2	G3	G6	G7

CLASS 1500

FULL BORE - Type 9S 100 - 9SHW 100						
SIZE	inch	1/2	3/4	1	1.1/2	2
	mm	15	20	25	40	50
A		110	127	127	210	230
B open		293	343	388	588	590
C		138	138	172	234	320
F		14	18	24	36,6	48
G		48	56	64	85	95
W. kg \cong Bolted B.		5	7	9,5	23,5	40
W. kg \cong Welded B.		4,5	6,5	8,3	22	37
FIGURE Bolted B.		9S 103	9S 104	9S 105	9S 107	9S 108
FIGURE Welded B.		9SHW 103	9SHW 104	9SHW 105	9SHW 107	9SHW 108
PACKING		BH5	BH6/A	2B4/A	2B5	9B8/A
GASKET*		G2	G3	G4	G7	G8

REDUCED BORE - Type 9SL 100 - 9SHWL 100						
SIZE	inch	1/2	3/4	1	1.1/2	2
	mm	15	20	25	40	50
A		90	110	127	127	210
B open		238	293	343	450	588
C		138	138	138	234	234
F		9,6	14	18	30	36,6
G		38	48	56	78	85
W. kg \cong Bolted B.		3	5	7	10	24
W. kg \cong Welded B.		2,8	4,6	6,5	9	22
FIGURE Bolted B.		9SL 103	9SL 104	9SL 105	9SL 107	9SL 108
FIGURE Welded B.		9SHWL 103	9SHWL 104	9SHWL 105	9SHWL 107	9SHWL 108
PACKING		BH3	BH5	BH6/A	2B5	BH8
GASKET*		G1	G2	G3	G5	G7

* Only for Bolted Bonnet type.

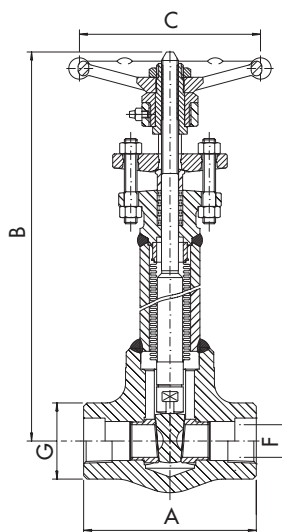
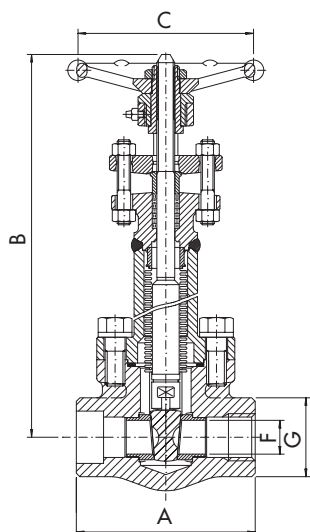

BELLOWS SEALED VALVES



Socket weld Ends to ANSI B16.11
 Screwed Ends (NPT) to ANSI B1.20.1
 Butt Welding Ends to ANSI B.16.25
 Face to face according to BFE standard

Ratings:
 - carbon steel class 800 1975 psig @ 100°F
 140 bar + 38°C
 - carbon steel class 1500 3555 psig @ 100°F
 250 bar + 38°C
 - carbon steel class 2500 5835 psig @ 100°F
 410 bar + 38°C

GLOBE VALVES

CLASS 800

FULL BORE - Type S 300 - SHW 300									
SIZE	inch	1/4	3/8	1/2	3/4	1	1.1/4	1.1/2	2
	mm	6	10	15	20	25	32	40	50
A		80	80	90	110	127	150	180	210
B open		190	190	195	225	271	315	356	429
C		88	88	88	97	138	138	172	172
F		7	9	13	17,5	22,5	29,5	35	45
G		32	32	38	48	56	64	78	85
W. kg ≅ Bolted B.		2,5	2,5	3,5	5,2	8,7	10	18,5	30,5
W. kg ≅ Welded B.		2,3	2,3	3,2	5	8	9	17	28
FIGURE Bolted B.		S 301	S 302	S 303	S 304	S 305	S 306	S 307	S 308
FIGURE Welded B.		SHW 301	SHW 302	SHW 303	SHW 304	SHW 305	SHW 306	SHW 307	SHW 308
PACKING		BH2	BH2	BH2	BH4	BH5	BH6/A	BY5	BH8
GASKET*		G2	G2	G2	G3	G4	G6	G7	G9

REDUCED BORE - Type SL 300 - SHWL 300						
SIZE	inch	1/2	3/4	1	1.1/2	2
	mm	15	20	25	40	50
A		80	90	110	150	180
B open		190	195	225	315	356
C		88	88	97	138	172
F		9	13	17,5	29,5	35
G		32	38	48	64	78
W. kg ≅ Bolted B.		2,5	2,7	4,3	8,8	13,5
W. kg ≅ Welded B.		2,2	2,4	3,5	8,1	11,8
FIGURE Bolted B.		SL 303	SL 304	SL 305	SL 307	SL 308
FIGURE Welded B.		SHWL 303	SHWL 304	SHWL 305	SHWL 307	SHWL 308
PACKING		BH2	BH2	BH4	BH6/A	BY5
GASKET*		G2	G2	G3	G6	G7

CLASS 1500

FULL BORE - Type 9S 300 - 9SHW 300						
SIZE	inch	1/2	3/4	1	1.1/2	2
	mm	15	20	25	40	50
A		110	127	150	210	230
B open		243	286	311	445	510
C		138	172	234	320	320
F		12	15	20	32	40
G		48	56	64	85	95
W. kg ≅ Bolted B.		4,5	7	9	23	38
W. kg ≅ Welded B.		4	6,5	8,3	22	36,5
FIGURE Bolted B.		9S 303	9S 304	9S 305	9S 307	9S 308
FIGURE Welded B.		9SHW 303	9SHW 304	9SHW 305	9SHW 307	9SHW 308
PACKING		BH5	2B4/A	2B4/A	BH8	9B8/A
GASKET*		G2	G3	G4	G7	G8

REDUCED BORE - Type 9SL 300 - 9SHWL 300						
SIZE	inch	1/2	3/4	1	1.1/2	2
	mm	15	20	25	40	50
A		90	110	127	180	210
B open		229	243	286	360	445
C		138	138	172	234	320
F		9	12	15	27	32
G		38	48	56	78	85
W. kg ≅ Bolted B.		3,5	4,5	7	9	23
W. kg ≅ Welded B.		3	4,6	6,5	8,9	21,5
FIGURE Bolted B.		9SL 303	9SL 304	9SL 305	9SL 307	9SL 308
FIGURE Welded B.		9SHWL 303	9SHWL 304	9SHWL 305	9SHWL 307	9SHWL 308
PACKING		BH3	BH5	2B4/A	2B5	BH8
GASKET*		G1	G2	G3	G5	G7

* Only for Bolted Bonnet type.

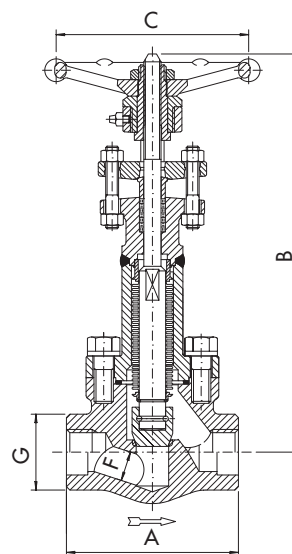
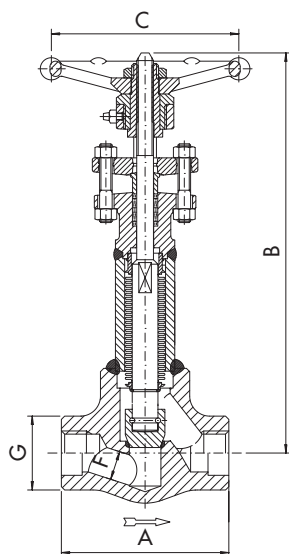

BELLOWS SEALED VALVES

For special execution see special features
 For materials and testing pressure see technical data

GATE VALVES

CLASS 2500									
FULL BORE - Type S25X 100									
SIZE	inch	1/4	3/8	1/2	3/4	1	1.1/4	1.1/2	2
	mm	6	10	15	20	25	32	40	50
A		110	110	127	127	127	127	210	230
B open		380	380	430	450	510	620	630	710
C		138	138	138	172	234	234	320	400
F		8	8	11,5	15	19,5	25	28	35
G		48	48	56	64	78	78	85	95
WEIGHT kg \cong		6,2	6,2	6,5	10,5	16	17	29	45
FIGURE		S25X 101	S25X 102	S25X 103	S25X 104	S25X 105	S25X 106	S25X 107	S25X 108
PACKING		BH6/A	BH6/A	2B4/A	2B4/A	BH8	BH8	9B8/A	25B8

GLOBE VALVES

CLASS 2500									
FULL BORE - Type S25YX 300									
SIZE	inch	1/4	3/8	1/2	3/4	1	1.1/2	2	
	mm	6	10	15	20	25	32	50	
A		105	105	120	165	165	190	220	
B open		350	350	370	400	440	490	570	
C		138	138	172	234	320	320	400	
F		7	9	11	14,5	19	28	35	
G		48	48	56	78	78	85	95	
WEIGHT kg \cong		6,5	6,5	8	15	18	24	38	
FIGURE		S25YX 301	S25YX 302	S25YX 303	S25YX 304	S25YX 305	S25YX 307	S25YX 308	
PACKING		BH7	BH7	BH7	BH8	9B8/A	9B8/A	4B7	

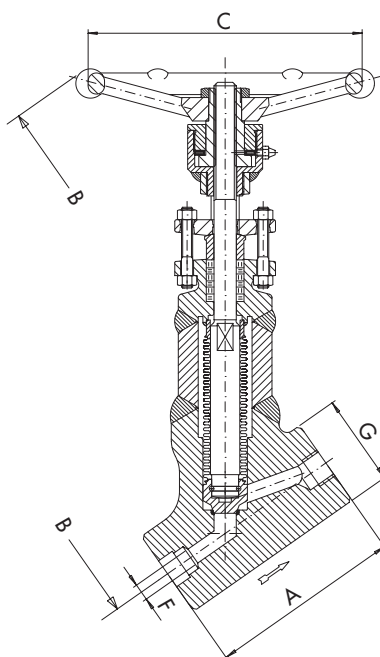

BELLOWS SEALED VALVES

